

UNCONTROLLED DOCUMENT

PART NUMBER		REV.
LCD-S601C71TF		A
REV.	E.C.N. NUMBER AND REVISION COMMENTS	DATE
A	E.C.N. #11148.	02.09.07

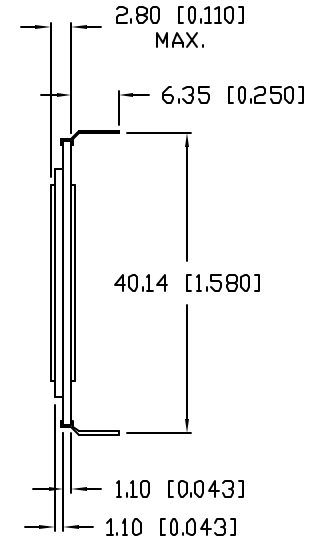

CHARACTERISTICS	
FLUID TYPE:	TN
BACKGROUND COLOR:	GRAY
VIEWING DIRECTION:	B:00
DISPLAY MODE:	TRANSFLECTIVE
OPERATING VOLTAGE:	3.0~5.0V AC.
OPERATING TEMP.	0°C TO 50°C
STORAGE TEMP.	-20°C TO 70°C
DRIVING METHOD:	STATIC
CONNECTION TYPE:	50 PINS

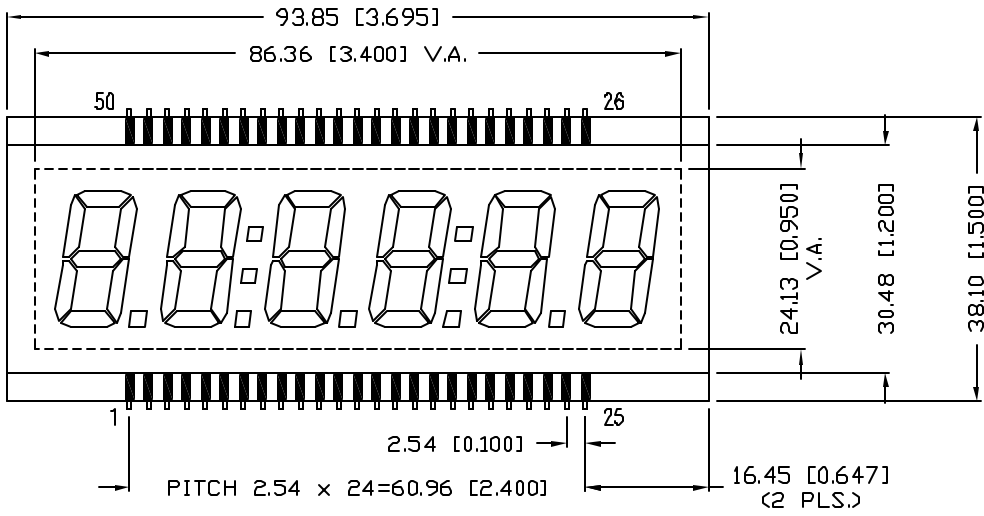
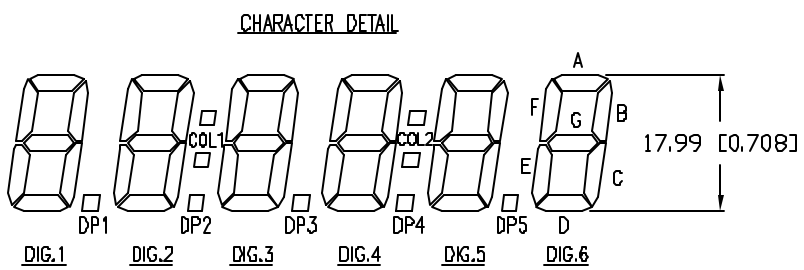

PIN NO.	1	2	3	4	5	6	7	8	9	10
SEGMENT	COM	1E	1D	1C	DP1	2E	2D	2C	DP2	3E
PIN NO.	11	12	13	14	15	16	17	18	19	20
SEGMENT	3D	3C	DP3	4E	4D	4C	DP4	5E	5D	5C
PIN NO.	21	22	23	24	25	26	27	28	29	30
SEGMENT	DP5	6E	6D	6C	6B	6A	6F	6G	5B	5A
PIN NO.	31	32	33	34	35	36	37	38	39	40
SEGMENT	5F	5G	CLN2	4B	4A	4F	4G	3B	3A	3F
PIN NO.	41	42	43	44	45	46	47	48	49	50
SEGMENT	3G	CLN1	2B	2A	2F	2G	1B	1A	1F	1G

UNCONTROLLED DOCUMENT

*UNLESS OTHERWISE SPECIFIED TOLERANCES PER DECIMAL PRECISION ARE: X=±1 (±0.039), XX=±0.5 (±0.020), XXX=±0.25 (±0.010), XXXX=±0.127 (±0.005). LEAD SIZE=±0.05 (±0.002), LEAD LENGTH=±0.75 (±0.030). MIN= +DECIMAL PRECISION -0.00 MAX.= +0.00 -DECIMAL PRECISION

REV.	PART NUMBER
A	LCD-S601C71TF
0.71" CHARACTER HEIGHT, 6 DIGIT LCD GLASS, TN, TRANSFLECTIVE, 50 PINS.	

CONFIDENTIAL INFORMATION
THE INFORMATION CONTAINED IN THIS DOCUMENT IS THE PROPERTY OF LUMEX INC. EXCEPT AS SPECIFICALLY AUTHORIZED IN WRITING BY LUMEX INC., THE HOLDER OF THIS DOCUMENT SHALL KEEP ALL INFORMATION CONTAINED HEREIN CONFIDENTIAL AND SHALL PROTECT SAME IN WHOLE OR IN PART FROM DISCLOSURE AND DISSEMINATION TO ALL THIRD PARTIES.

RELIABILITY NOTE
OUR MANY YEARS OF EXPERIENCE DATA ACCUMULATION INDICATE THAT SOLDER HEAT IS A MAJOR CAUSE OF EARLY AND FUTURE FAILURE. PLEASE PAY ATTENTION TO YOUR SOLDERING PROCESS.



290 E. HELEN ROAD
PALATINE, IL 60067-6976
PHONE: +1.847.359.2790
US WEB: www.lumex.com
TW WEB: www.lumex.com.tw

DRAWN BY:	CHECKED BY:	APPROVED BY:	DATE:
jc			10.20.99
			PAGE: 1 OF 1
			SCALE: N/A